

# DATASHEET

## QUICK-MULTICLAMP 250KG / 50MM

■ Art.Nr. 151 50 250 10 Q  
 ■ Art.Nr. 151 50 250 10 Q BK

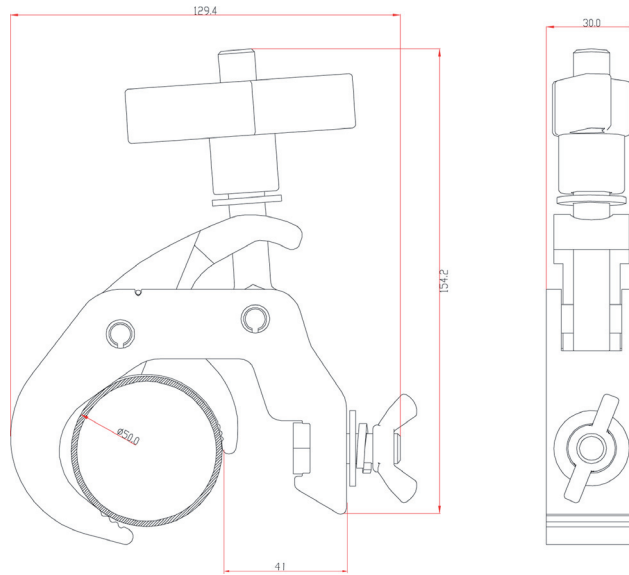

<b>Rohrdurchmesser</b> <i>Tube</i>	48-51 mm
<b>Belastbarkeit (SWL)</b> <i>Tensile load</i>	250 kg
<b>Farbe</b> <i>Colour</i>	silber / schwarz <i>silver / black</i>
<b>Bauform</b> <i>Variaty</i>	Schnellspann-Klemme <i>Quick-lock clamp</i>
<b>Verschluss</b> <i>Screw plug</i>	M12 Flügelmutter groß, Unterlegscheibe <i>M12 wing nut big, washer</i>
<b>Abgang</b> <i>Retaining screw</i>	M10 Geräteschraube, Flügelmutter <i>M10 bolt, wing nut</i>
<b>Breite</b> <i>Width</i>	30 mm
<b>Zugbelastung</b> <i>Tensile load</i>	250 kg
<b>Material</b> <i>Material</i>	Aluminium 6061 T6
<b>Gewicht</b> <i>Weight</i>	0,50 kg
<b>Verpackungseinheit</b> <i>Unit</i>	20 Stück <i>20v pieces</i>